

Cast Iron Valves

JIS 5K/10K, Class 125



STANDARD PRODUCTION RANGE

Valve type	Nominal Pressure	Fig. No.	Construction (Note)	Page
Gate valves	JIS 5K	5FCM	B.B./O.S.&Y.	4
	JIS 10K	10FCL	B.B./O.S.&Y.	4
	JIS 10K	10FCLS	B.B./O.S.&Y.	4
	JIS 10K	10FCLU	B.B./O.S.&Y.	4
	JIS 10K	10FCWI	B.B./I.S./N.R.S.	5
	10K	10FCHI	B.B./I.S./N.R.S.	5
	Class 125	125FCL	B.B./O.S.&Y.	6
	Class 125	125FCLS	B.B./O.S.&Y.	6
	Class 125	125FCWI	B.B./I.S./N.R.S.	6
	Class 125	125FCHI		7
Globe valves	JIS 10K	10FCJ	B.B./O.S.&Y.	8
	JIS 10K	10FCJS	B.B./O.S.&Y.	8
	JIS 10K	10FCJU	B.B./O.S.&Y.	8
	Class 125	125FCJ	B.B./O.S.&Y.	8
	Class 125	125FCJS	B.B./O.S.&Y.	8
Swing check valves	JIS 10K	10FCO	Bolted cover	9
	JIS 10K	10FCOS	Bolted cover	9
	JIS 10K	10FCOU	Bolted cover	9
	Class 125	125FCO	Bolted cover	9
	Class 125	125FCOS	Bolted cover	9
	10K	10FWZ	Wafer type	10
Strainers	10K	10FCY	Bolted cover	10
	Class 125	125FCY	Bolted cover	11
Ball valves	10K	10FCT	Full bore	12
	10K	10FCTB	Full bore	12
	10K	10FCTR	Reduced bore	13
	10K	10FCTB2L	Full bore, 3-way	13
	10K	10FCTR2L	Reduced bore, 3-way	13
	Class 125	125FCTB	Full bore	14
	Class 125	125FCTR	Reduced bore	14

Product Coding

EX:

125	FC	L	S
↓	↓	↓	↓
1	2	3	4

- 1 Nominal Pressure
 125 Class 125
 5 JIS 5K
 10 JIS 10K

- 2 Symbol of shell material
 FC Cast Iron
- 3 Type of valve
 L Gate valve
 WI & HI... Gate valve with indicator
 J Globe valve
 O Check valve
 TB Full port ball valve
 TR Reduced port ball valve

- 4 Trim material
 None Bronze trim
 U 18-8 stainless steel
 S 13Cr stainless steel

NOTE

B.B. Bolted bonnet
 O.S.&Y ... Outside screw & yoke
 I.S. Inside screw
 N.R.S. Non-rising stem

Basic Design Specifications

Nominal Pressure	JIS5K/10K	Class 125	10K
Face to face dimension	JIS B 2031	ASME B 16.10	KITZ Std.
End flange dimension	JIS B 2239	ASME B 16.1	JIS B 2239
Wall thickness	JIS B 2031	KITZ Std.	

Material Specifications for Grey Iron Casting

Mechanical Properties	JIS materials	FC200	FC250	FC300
	Tensile strength (N/mm ²)	min.	200	250
Brinell hardness (HB) max.		235	248	269
ASTM A126 Class B	Tensile strength (min)	31ksi		
Transverse test requirement	Face at center, min.	3,300 lb		
	Deflection at center, min.	0.12in		

ASME Valves Pressure-Temperature Ratings

Maximum Allowable Non-Shock Pressure

temperature	Class 125	
	Size 1 – 12	Size 14 – 24
°C	bar	
-29 to 65	13.8	10.3
80	13.3	9.8
100	12.7	9.2
120	12.1	8.6
140	11.5	8.0
160	10.8	7.4
178※	—	6.9
180	10.2	—
200	9.6	—
220	9.0	—
232	8.6	—

※178°C to reflect the temperature of saturated steam at 8.6 bar.

JIS Valves Pressure-Temperature Ratings MPa

Service temperature °C (°F)	JIS 5K	JIS 10K	10K	
	All Sizes	Sizes 2" to 12"	Sizes 14" to 24"	FC300 all sizes
120°(248°) non-shock water	0.69	1.37	0.98	0.98
120°(248°) oil, water, air	0.49	0.98	0.86	0.86
Saturated steam	0.20	0.69/*0.20	0.69	0.69

*Inside screw gate valves only.

Simplified Material Indication (as referred to in each page)

- Bronze trim** : Iron body with bronze trim
- 13 Cr. trim** : Iron body with 13 Cr. trim
- 18-8 trim** : Iron body with 18 Cr.-8 Ni trim

Certification by JIS Mark

Industrial Standardization Law of Japan provides an effective measure to promote introduction of high level quality assurance system of manufacture and processing. Wherever KITZ valves are identified with JIS Mark, it is officially certified that such valves are produced under strict quality assurance procedures and practices to satisfy the designated quality level stably and constantly.

Valve Position Indicators



A valve position indicator is provided on gate valves with inside screw design as illustrated here. Opening or closing valves does not move the vertical position of the stem. Instead, the position indicator visually indicates three valve operating positions—fully opened, fully closed or half opened.

Trim Materials

KITZ cast iron valves are provided with either one of the three trim materials tabled below for versatility of service applications.

Color coding is made on a spoke of the handwheel of gate or globe valves and on the cover of swing check valves.

Trim material	Color coding	Suffix of Fig.
■ Bronze seats / Brass stem	None	—
■ 13 Cr. seats / stem	Yellow	S
■ 18-8 seats / stem	Red	U

Outside Screw (O.S.) Valves and Inside Screw (I.S.) Valves

Outside Screw Gate Valve

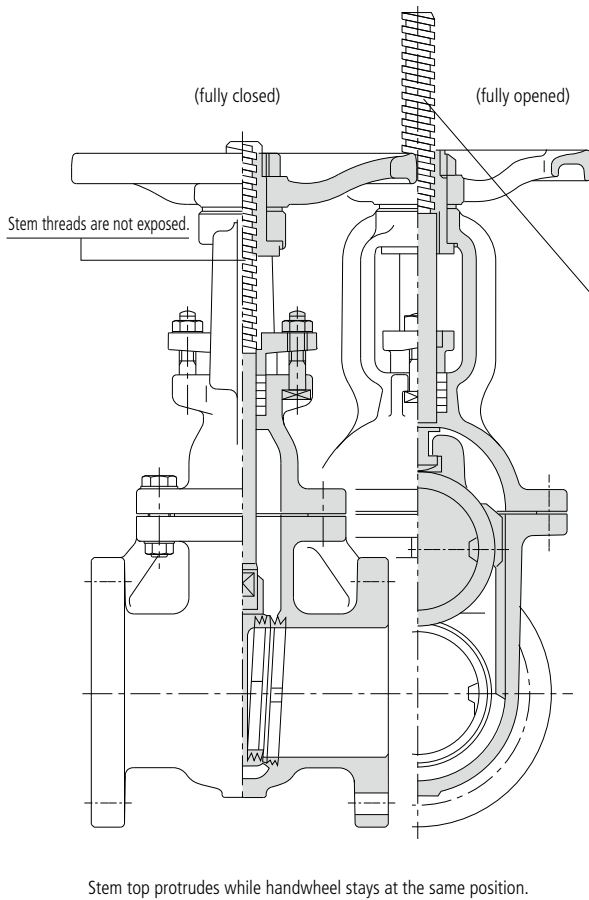

Inside Screw Gate Valve

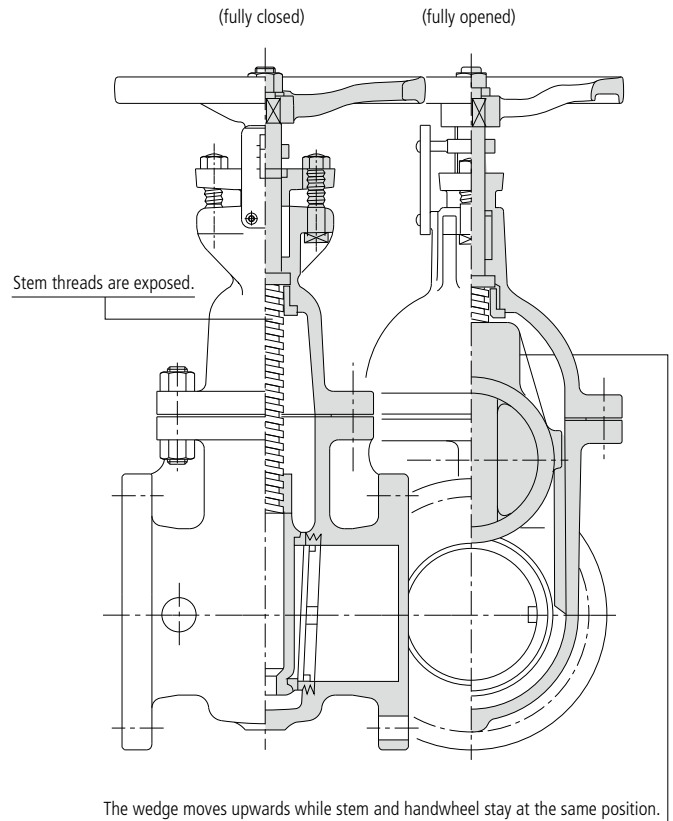

Outside Screw Gate Valves

Stem threads are not exposed to the fluid, and valve opening operation moves the stem upwards while the handwheel stays at the same position. Valve operating position can be visually known by observing stem travel KITZ Fig. FCM, FCL, FCLS and FCLU are designed this way.

Outside Screw Globe Valves

The stem and handwheel move upwards or downwards at the same time, following valve opening or closing operation. All KITZ globe valves are provided with this design.

Inside Screw Gate Valves

Stem threads are exposed to the fluid and valve opening operation does not make movement of the stem or handwheel so that valve operating position is not visible. A position indicator is provided for this reason.

Inside screw gate valves are generally designed shorter than outside screw gate valves and the stem and handwheel stay always at the same position. For this feature, inside screw gate valves are widely employed for underground installation or service in narrow areas with limited room. KITZ Fig. FCWI and FCHI are designed this way.

Asbestos-free Packings and Gaskets

KITZ has led the industry in employing asbestos-free sealers for all cast iron valves, meeting the requirement of pollution-free valve materials. PTFE impregnated glass fiber gland packings and compressed glass and aramid fiber gaskets are the standard sealers for KITZ cast iron valves.

JIS 5K

IRON GATE VALVE

Bolted bonnet, outside screw & yoke, rising stem.

Designed to JIS B2031

Fig. 5FCM

- Bronze trim

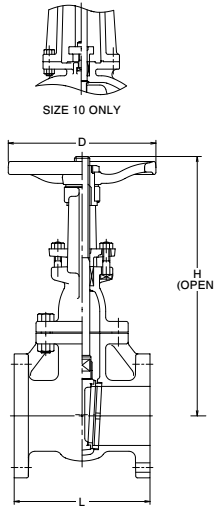

Materials

Parts	Material	JIS Spec.
Body	Cast Iron	FC200
Bonnet	Cast Iron	FC200
Stem	Forged Brass	C3771BD
Disc	Cast Iron	FC200
Disc seat ring	Bronze	CAC406
Body seat ring	Bronze	CAC406
Gland	Ductile Iron	FCD-S
Gland packing	Asbestos-free	
Gasket	Asbestos-free	
Gland bolt/nut	Carbon Steel	
Bonnet bolt/nut	Carbon Steel	
Yoke sleeve	Bronze	CAC406
Hand wheel	Cast Iron	FC250

For JIS Valves Pressure-Temperature Ratings MPa, refer to page 2.

Dimensions

Valve Size	B	2	2 1/2	3	4	5	6	8	10	mm
L Face-to-face	A	50	65	80	100	125	150	200	250	
H Height (OPEN)		328	382	436	532	627	726	919	1134	
D Handwheel Diameter		160	170	170	225	225	250	280	350	

JIS 10K

IRON GATE VALVE

Bolted bonnet, outside screw & yoke, rising stem.

Designed to JIS B2031

Fig. 10FCL

- Bronze trim

Fig. 10FCLS

- Stainless steel trim (13 Cr.)

Fig. 10FCLU

- Stainless steel trim (18-8)

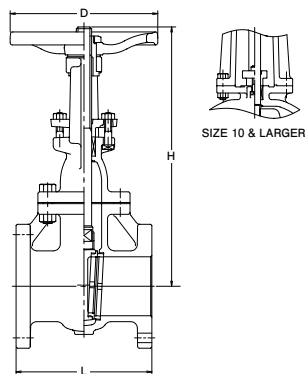

Materials

Parts	Material	JIS Spec.		
		10FCL	10FCLS	10FCLU
Body	Cast Iron	FC200		
Bonnet	Cast Iron	FC200		
Stem	Brass/Stainless Steel	C3771BD	SUS403	SUS304
Disc	Cast Iron	FC200		
Disc seat ring	Brass/Stainless Steel	CAC406	SUS403	SUS304
Body seat ring	Bronze	CAC406	SUS403	SUS304
Gland	11/2 to 14 16 to 24	Ductile Iron	FCD-S	
		Stainless Steel	SUS403	
Gland packing	Asbestos-free			
Gasket	Asbestos-free			
Gland bolt/nut	Carbon Steel			
Bonnet bolt/nut	Carbon Steel			
Yoke sleeve	Bronze	CAC406		
Hand wheel	11/2 to 8 10 to 24	Cast Iron	FC250	
		Ductile Iron	FCD400	

For JIS Valves Pressure-Temperature Ratings MPa, refer to page 2.

Dimensions

Valve Size	B	1 1/2*	2	2 1/2	3	4	5	6	8	10	12	14*	16*	18*	20*	24*	mm
L Face-to-face	A	40	50	65	80	100	125	150	200	250	300	350	400	450	500	600	
H Height (OPEN)		306	343	389	462	547	648	759	956	1168	1363	1560	1795	1995	2230	2640	
D Handwheel Diameter		160	170	170	200	250	280	300	350	400	450	500	600	600	680	760	

*JIS Mark is not applicable

JIS 10K

IRON GATE VALVE

Bolted bonnet, inside screw with indicator, non-rising stem.

Designed to JIS B2031

Fig. 10FCWI

- Bronze trim



SIZE 8 & LARGER

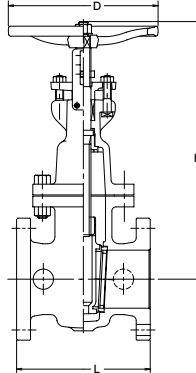

Materials

Parts	Material	JIS Spec.
Body	Cast Iron	FC200
Bonnet	Cast Iron	FC200
Stem	Forged Brass	C3771BD
Disc	Cast Iron	FC200
Disc seat ring	Bronze	CAC406
Body seat ring	Bronze	CAC406
Gland	Ductile Iron	FCD-S
Gland packing	Asbestos-free	
Gasket	Asbestos-free	
Gland bolt/nut	Carbon Steel	
Bonnet bolt/nut	Carbpn Steel	
Bonnet bushing	Bronze	CAC406
Hand wheel	1 1/2 to 8	Cast Iron
	10 to 12	Ductile Iron

For JIS Valves Pressure-Temperature Ratings MPa, refer to page 2.

Dimensions

Valve Size	B	1 1/2	2	2 1/2	3	4	5	6	8	10	12	mm
	A	40*	50	65	80	100	125	150	200	250	300	
L Face-to-face		165	180	190	200	230	250	270	290	330	350	
H Height		285	313	344	401	444	517	577	693	814	925	
D Handwheel Diameter		160	180	180	200	250	280	300	350	400	450	

*No JIS Mark

10K

IRON GATE VALVE

Bolted bonnet, inside screw with indicator, non-rising stem.

Fig. 10FCHI

- Bronze trim



SIZE 8 & LARGER

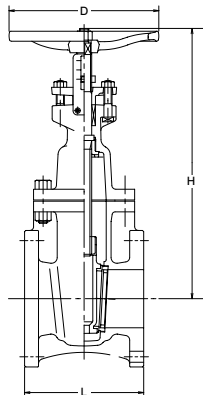

Materials

Parts	Material	JIS Spec.
Body	Cast Iron	FC300
Bonnet	Cast Iron	FC300
Stem	Forged Brass	C3771BE
Disc	1 1/2	Bronze
	2 to 12	Cast Iron
Disc seat ring	Bronze	CAC406
Body seat ring	Bronze	CAC406
Gland	Ductile Iron	FCD-S
Gland packing	Asbestos-free	
Gasket	Asbestos-free	
Gland bolt/nut	Carbon Steel	
Bonnet bolt/nut	Carbpn Steel	
Bonnet bushing	Bronze	CAC406
Hand wheel	Cast Iron	FC250

120°C Non-shock water 1.0 MPa, 120°C Water, oil, air 0.9 MPa
Saturated steam 0.7 MPa

Dimensions

Valve Size	B	1 1/2	2	2 1/2	3	4	5	6	8	10	12	mm
	A	40	50	65	80	100	125	150	200	250	300	
L Face-to-face		140	146	159	165	171	190	210	241	273	305	
H Height		210	250	285	350	400	460	515	635	760	870	
D Handwheel Diameter		140	140	160	160	180	225	225	300	350	350	

Class 125 IRON GATE VALVE

Bolted bonnet, outside screw & yoke, rising stem.

Fig. 125FCL

- Bronze trim



Fig. 125FCLS

- Stainless steel trim (13 Cr.)

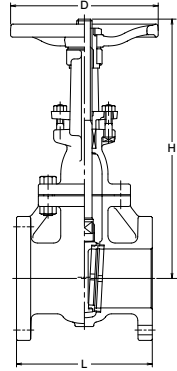

Materials

Parts	Material	ASTM Spec.	
		125FCL	125FCLS
Body	Cast Iron	A126 CL. B	
Bonnet	Cast Iron	A126 CL. B	
Stem	Brass/Stainless Steel	B124 C37700	A276 Type403
Disc	Cast Iron	A126 CL. B	
Disc seat ring	Bronze/Stainless Steel	B62	A182 Gr.F6a
Body seat ring	Bronze	B62	A182 Gr.F6a
Gland	Ductile Iron		
Gland packing	Asbestos-free		
Gasket	Asbestos-free		
Gland bolt/nut	Carbon Steel		
Bonnet bolt/nut	Carbon Steel		
Yoke sleeve	Bronze	B62	
Hand wheel	2 to 10	Cast Iron	
	12 & 14	Ductile Iron	

For ASME Valves Pressure-Temperature Ratings, refer to page 2.

Dimensions

Valve Size	NPS DN	2	2 1/2	3	4	5	6	8	10	12	14
L Face-to-face		178	190	203	229	254	267	292	330	356	381
H Height (OPEN)		328	382	436	532	627	726	919	1134	1363	1560
D Handwheel Diameter		160	170	170	225	225	250	280	350	450	500

Class 125 IRON GATE VALVE

Bolted bonnet, inside screw with indicator, non-rising stem.

Fig. 125FCWI

- Bronze trim

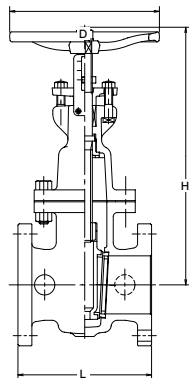

Materials

Parts	Material	ASTM Spec.
Body	Cast Iron	A126 CL. B
Bonnet	Cast Iron	A126 CL. C
Stem	Forged Brass	B124 C37700
Disc	Cast Iron	A126 CL. C
Disc seat ring	Bronze	B62
Gland	Ductile Iron	
Gland packing	Asbestos-free	
Gasket	Asbestos-free	
Gland bolt/nut	Carbon Steel	
Bonnet bolt/nut	Carbon Steel	
Body seat ring	Bronze	B62
Bonnet bushing	Bronze	B62
Hand wheel	Cast Iron	A126 CL. B

For ASME Valves Pressure-Temperature Ratings, refer to page 2.

Dimensions

Valve Size	NPS DN	2	2 1/2	3	4	5	6	8	10	12
L Face-to-face		178	190	203	229	254	267	292	330	356
H Height		250	285	350	400	465	515	630	760	870
D Handwheel Diameter		140	160	160	180	225	225	300	350	350

Class 125

IRON GATE VALVE

Bolted bonnet, inside screw & yoke, non-rising stem.

Fig. 125FCHI

- Bronze trim



SIZE 8 ONLY

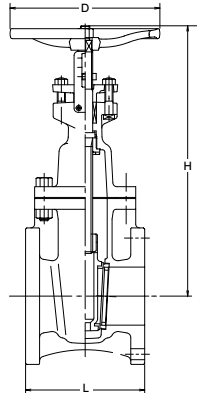

Materials

Parts	Material	ASTM Spec.	
Body	Cast Iron	A126 CL. C	
Bonnet	Cast Iron	A126 CL. C	
Stem	Forged Brass	B124 C37700	
Disc	1 1/2	Bronze	B62
	2 & larger	Cast Iron	A126 CL. C
Disc seat ring	Bronze	B62	
Body seat ring	Bronze	B62	
Gland	Ductile Iron		
Gland packing	Asbestos-free		
Gasket	Asbestos-free		
Gland bolt/nut	Carbon Steel		
Bonnet bolt/nut	Carbon Steel		
Bonnet bushing	Bronze	B62	
Hand wheel	Cast Iron	A126 CL. B	

Design Specifications

Items	
Shell wall thickness and general valve design	KITZ Standard
Face-to-face dimensions End-to-end dimensions	KITZ Standard
End flange dimensions Gasket contact facing	ASME B16.1 Class 125

For ASME Valves Pressure-Temperature Ratings, refer to page 2.

Dimensions

Valve Size	NPS	1 1/2	2	2 1/2	3	4	5	6	8	mm
	DN	40	50	65	80	100	125	150	200	
L Face-to-face		140	146	159	165	171	190	210	241	
H Height		210	250	285	350	400	465	575	630	
D Handwheel Diameter		140	140	160	160	180	225	225	300	

Mounting of Seat Rings

In case of KITZ cast iron gate valves, seat rings are mounted on the valve disc either by means of threading or press-fitting. For example, 10K outside screw gate valves are provided with threaded seat rings which are ideal for saturated steam service. Or, 10K inside screw gate valves are provided with mechanically press-fit seat rings by means of patented special process to suit them also for saturated steam service. All KITZ cast iron globe and check valves are provided with threaded seat rings.

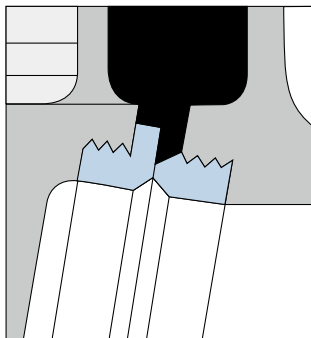

Threaded seat ring

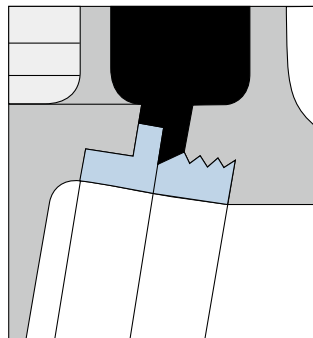

Press-fit seat ring

JIS 10K

IRON GLOBE VALVE

Bolted bonnet, outside screw & yoke, rising stem.

Designed to JIS B2031

Fig. 10FCJ

- Bronze trim

Fig. 10FCJS

- Stainless steel trim (13 Cr.)

Fig. 10FCJU

- Stainless steel trim (18-8)

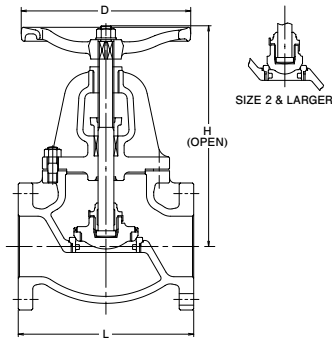

Materials

Parts	Material	JIS Spec.		
		10FCJ	10FCJS	10FCJU
Body	Cast Iron		FC200	
Bonnet	Cast Iron		FC200	
Stem	Brass/Stainless Steel	C3771BD	SUS403	SUS304
Disc	1 1/4 & 2	Brass/Stainless Steel	CAC406	SUS403
	2 1/2 & larger	Cast Iron		FC200
Disc seat ring	Brass/Stainless Steel	CAC406	SUS403	SUS304
Body seat ring	Bronze	CAC406	SUS403	SUS304
Gland	1 1/2 to 1 1/4	Ductile Iron		FCD-5
Gland packing			Asbestos-free	
Gasket			Asbestos-free	
Gland bolt/nut			Carbon Steel	
Bonnet bolt/nut			Carbon Steel	
Yoke bushing	Bronze		CAC406	
Hand wheel	1 1/2 to 6	Cast Iron		FC250
	8 only	Ductile Iron		FCD400
	10 only	Cast Iron		FC200

For JIS Valves Pressure-Temperature Ratings MPa, refer to page 2.

Dimensions

Valve Size	B	1 1/2	2	2 1/2	3	4	5	6	8
	A	40	50	65	80	100	125	150	200
L Face-to-face		190	200	220	240	290	360	410	500
H Height (OPEN)		260	277	307	353	404	454	533	642
D Handwheel Diameter		160	180	180	225	280	300	350	450

CLASS 125

IRON GLOBE VALVE

Bolted bonnet, outside screw & yoke, rising stem.

Fig. 125FCJ

- Bronze trim

Fig. 125FCJS

- Stainless steel trim (13 Cr.)

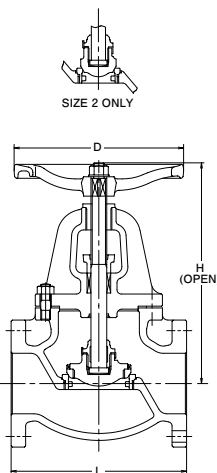

Materials

Parts	Material	ASTM Spec.	
		125FCJ	125FCJS
Body	Cast Iron	A126 CL. B	
Bonnet	Cast Iron	A126 CL. B	
Stem	Brass/Stainless Steel	B124 C37700	A276 type403
Disc	2 only	Brass/Stainless Steel	B62
	2 1/2 & larger	Cast Iron	A126 CL. B
Disc seat ring	Brass/Stainless Steel	B62	A276 type403
Body seat ring	Bronze	B62	A276 type403
Gland		Ductile Iron	
Gland packing		Asbestos-free	
Gasket		Asbestos-free	
Gland bolt/nut		Carbon Steel	
Bonnet bolt/nut		Carbon Steel	
Yoke bushing	Bronze		B62
Hand wheel	2 to 6	Cast Iron	
	8 only	Ductile Iron	

For ASME Valves Pressure-Temperature Ratings, refer to page 2.

Dimensions

Valve Size	NPS	2	2 1/2	3	4	5	6	8
	DN	50	65	80	100	125	150	200
L Face-to-face		203	216	241	292	330	356	495
H Height (OPEN)		277	307	353	404	454	533	642
D Handwheel Diameter		180	180	225	280	300	350	450

JIS 10K

IRON SWING CHECK VALVE

Bolted cover, swing type disc.

Designed to JIS B2031

Fig. 10FCO

- Bronze trim

Fig. 10FCOS

- Stainless steel trim (13 Cr.)

Fig. 10FCOU

- Stainless steel trim (18-8)

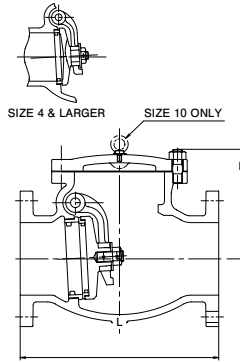

Materials

Parts	Material	JIS Spec.		
		10FCO	10FCOS	10FCOS
Body	Cast Iron		FC200	
Cover	Cast Iron		FC200	
Hinge pin	Brass/Stainless Steel	C3771BD	SUS403	SUS304
Disc	1 1/4 & 4	Brass/Stainless Steel	CAC406	SUS403
	5 & larger	Cast Iron		FC200
Disc seat ring	Brass/Stainless Steel	CAC406	SUS403	SUS304
Body seat ring	Bronze	CAC406	SUS403	SUS304
Arm	Stainless Steel		SCS13A	
Gasket		Asbestos-free		
Cover bolt/nut		Carbon Steel		

For JIS Valves Pressure-Temperature Ratings MPa, refer to page 2.

Dimensions

Valve Size	B	1 1/2*	2	2 1/2	3	4	5	6	8	10*	12*	14*	mm
L Face-to-face	A	40	50	65	80	100	125	150	200	250	300	350	
H Height		190	200	220	240	290	360	410	500	620	700	787	
		106	111	121	145	165	207	225	268	315	356	381	

Only 12" & 14" for 10FCOS & 10FCOU. *No JIS Mark

CLASS 125

IRON SWING CHECK VALVE

Bolted cover, swing type disc.

Fig. 125FCO

- Bronze trim

Fig. 125FCOS

- Stainless steel trim (13 Cr.)

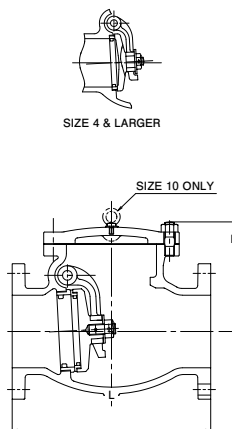

Materials

Parts	Material	ASTM Spec.	
		125FCO	125FCOS
Body	Cast Iron	A126 CL. B	
Cover	Cast Iron	A126 CL. B	
Hinge pin	Brass/Stainless Steel	B124 C37700	A276 Type403
Disc	2 to 4	Brass/Stainless Steel	B62
	5 & larger	Cast Iron	A126 CL. B
Disc seat ring	Brass/Stainless Steel	B62	A182 Gr.F6a
Body seat ring	Brass/Stainless Steel	B62	A182 Gr.F6a
Arm	Stainless Steel	A351 Gr.CF8	
Gasket		Asbestos-free	
Cover bolt/nut		Carbon Steel	

For ASME Valves Pressure-Temperature Ratings, refer to page 2.

Dimensions

Valve Size	NPS	2	2 1/2	3	4	5	6	8	10	mm
L Face-to-face	DN	50	65	80	100	125	150	200	250	
H Height (OPEN)		203	216	241	292	330	356	495	622	
		111	121	145	165	207	225	268	315	

10K

IRON WAFER TYPE CHECK VALVE

Fig. 10FWZ

• Bronze trim

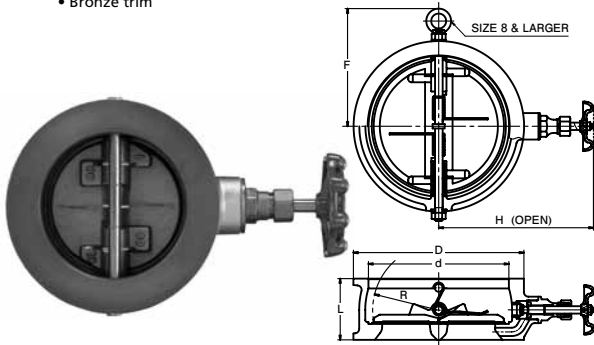

Materials

Parts	Material	JIS Spec.
Body	Cast Iron	FC250+NBR
Pin	Stainless Steel	SUS304
Disc	Bronze	CAC406
Nut 6 to 18	Stainless Steel	SUS304
Plug 1 1/2 to 5	Carbon Steel	S45CH

Bypass Valve

Parts	Material	JIS Spec.
Bonnet 1 1/2 to 5	Brass	C3771BE
6 to 18	Bronze	CAC406
Stem	Brass	C3531
Disc	Brass	C3531
Body seat ring	Brass	C3531
Grand packing	Asbestos-free	

Design Specifications

Items	
Shell wall thickness and general valve design	KITZ Standard
Face-to-face dimensions End-to-end dimensions	KITZ Standard
End flange dimensions Gasket contact facing	Wafer Type (JIS 10K)

80°C Non-shock water 1.4MPa

80°C Water, oil, air 1.0MPa

mm

Dimensions

Valve Size	B	1 1/2	2	2 1/2	3	4	5	6	8	10	12	14	16	18
	A	40	50	65	80	100	125	150	200	250	300	350	400	450
L		54	56	56	59	66	72	78	96	109	145	184	191	204
H Height (OPEN)		128	143	150	156	169	183	216	243	290	315	330	355	388
F		—	—	—	—	—	—	—	187	229	254	272	301	338
D		86	101	121	131	156	187	217	267	330	375	420	483	538
d		54	63	77	90	116	143	169	220	273	324	356	406	457
R		26	33	37	44	55	67	78	105	129	155	170	195	220

10K

IRON Y-PATTERN STRAINER

Bolted cover, Y-pattern body, Punched stainless steel plate screen.

Fig. 10FCY

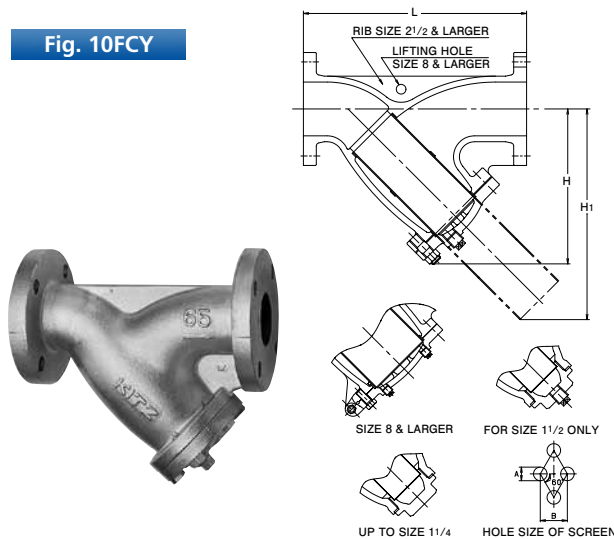

Materials

Parts	Material	JIS Spec.
Body	Cast Iron	FC200
Cap 3/8 to 1 1/2	Brass	C3771BE
Cover 2 & larger	Cast Iron	FC200
Screen	Stainless Steel	SUS304
Gasket	Asbestos-free	
Cover bolt/nut	Carbon Steel	
Plug 1 1/2 to 6	Stainless Steel	SUS304

Screen dimensions

Valve Size	A	P
3/8 to 2	1.4ø	2.4mm
2 1/2 to 5	1.5ø	2.5mm
6 & 8	3.0ø	5.0mm
10 & 14	5.0ø	7.0mm

120°C Non-shock water 1.4 MPa, 120°C Water, oil, air 1.0 MPa

120°C Gas 0.2 MPa, Saturated steam 0.7 MPa

Strainer dimensions

Valve Size	B	3/8	1/2	3/4	1	1 1/4	1 1/2	2	2 1/2	3	4	5	6	8	10	12	14
	A	10	15	20	25	32	40	50	65	80	100	125	150	200	250	300	350
L Face-to-face		115	125	140	150	170	190	230	305	360	415	465	515	580	680	800	950
H Height		46	57	63	77	90	100	127	208	237	280	325	370	457	536	625	741
H1		64	82	91	114	134	146	173	289	335	388	446	497	643	768	893	1047

mm

CLASS 125

IRON Y-PATTERN STRAINER

Bolted cover, Y-pattern body, Punched stainless steel plate screen.

Fig. 125FCY

- Bronze trim

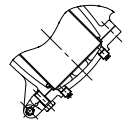
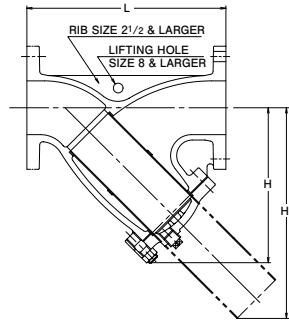

SIZE 8 & LARGER HOLE SIZE OF SCREEN

Materials

Parts	Material	ASTM Spec.
Body	Cast Iron	A126 CL.B
Cover	Cast Iron	A126 CL.B
Screen	Stainless Steel	A167 Type304
Gasket	Asbestos-free	
Cover bolt/nut	Carbon Steel	A307 Gr.B
Plug	1 1/2 to 6 Stainless Steel	A276 Type304

Screen dimensions

Valve Size	A	P
2 only	1.4ø	2.4mm
2 1/2 to 5	1.5ø	2.5mm
6 & 8	3.0ø	5.0mm
10 & 12	5.0ø	7.0mm

Design Specifications

Items	
Shell wall thickness and general valve design	KITZ Standard
Face-to-face dimensions End-to-end dimensions	KITZ Standard
End flange dimensions Gasket contact facing	ASME B16.1 Class125

For ASME Valves Pressure-Temperature Ratings, refer to page 2.

Dimensions

Valve Size	NPS	2	2 1/2	3	4	5	6	8	10	12	14	mm
	DN	50	65	80	100	125	150	200	250	300	350	
L Face-to-face		250	285	315	370	420	490	570	680	800	950	
H Height		168	212	242	284	325	370	440	515	600	740	
H1		208	289	335	388	446	497	589	694	818	993	



10K

IRON THREADED BALL VALVE (Full bore)

Fig. 10FCT

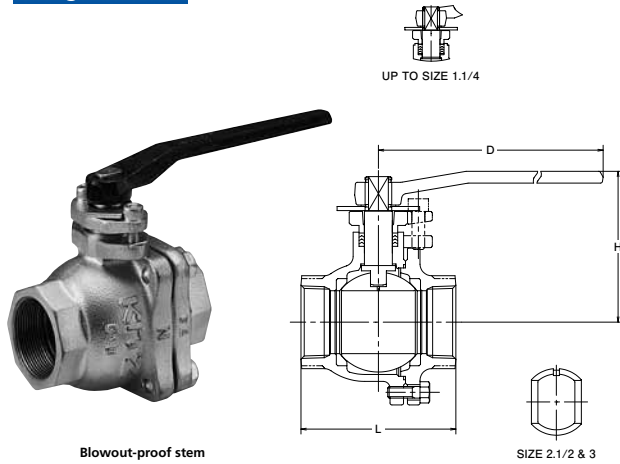

Materials

Parts	Material	JIS Spec.
Body	Cast Iron	FC200
Body cap	Cast Iron	FC200
Stem	Stainless Steel	SUS403
Ball	Stainless Steel	SCS13A or SUS304 or SUS304TP
Grand packing	PTFE	
Gasket	PTFE	
Ball Seat	PTFE	
Cap bolt	Carbon Steel	
Handle	Ductile Iron	FCD400

Design Specifications

Items	
Shell wall thickness and general valve design	KITZ Standard
Face-to-face dimensions End-to-end dimensions	KITZ Standard
Threaded ends	JIS B0203

For Pressure-Temperature Ratings, refer to individual catalog.

Dimensions

Valve Size	B	3/8	1/2	1/2	1	1 1/4	1 1/2	2	2 1/2	3	mm
L Face-to-face	A	72	80	85	95	120	120	140	160	182	
H Height		71	102	105	125	130	115	120	155	165	
D Handle		130	130	130	160	160	230	230	400	400	

10K

IRON BALL VALVE (Full bore)

Fig. 10FCTB

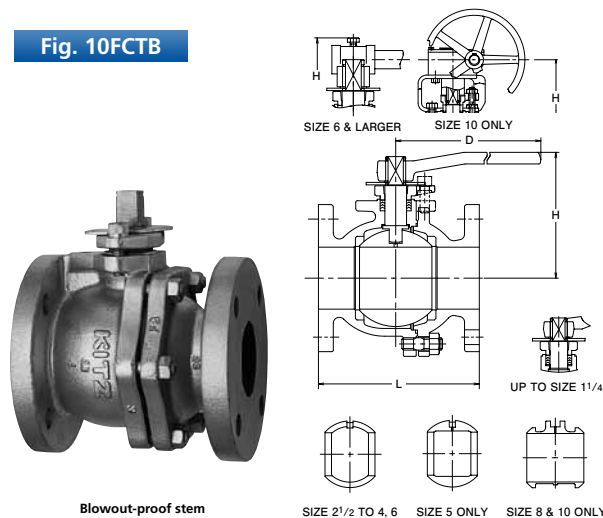

Materials

Parts	Material	JIS Spec.
Body	Cast Iron	FC200
Body cap	Cast Iron	FC200
Stem	Stainless Steel	SUS403
Ball	Stainless Steel	SCS13A or SUS304 or SUS304TP
Grand packing	PTFE	
Gasket	PTFE	
Ball Seat	PTFE	
Cap bolt	Carbon Steel	
Handle	Ductile Iron	FCD400

Design Specifications

Items	
Shell wall thickness and general valve design	KITZ Standard
Face-to-face dimensions End-to-end dimensions	KITZ Standard
End flange dimensions Gasket contact facing	JIS B2239 10K

For Pressure-Temperature Ratings, refer to individual catalog.

Dimensions

Valve Size	B	1/2	3/4	1	1 1/4	1 1/2	2	2 1/2	3	4	5	6	8	10	mm
L Face-to-face	A	110	120	130	140	165	180	190	200	230	300	340	450	533	
H Height		102	105	124	128	114	121	154	163	199	219	292	352	477	
D Handle		130	130	160	160	230	230	400	400	460	460	1000	1500	-	

*Note: Gear Operated. Contact KITZ or KITZ distributors for details.

10K

IRON BALL VALVE (Reduced bore)

Fig. 10FCTR



Blowout-proof stem

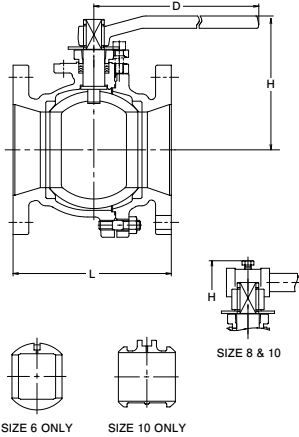

SIZE 6 ONLY SIZE 10 ONLY

Materials

Parts	Material	JIS Spec.
Body	Cast Iron	FC200
Body cap	Cast Iron	FC200
Stem	Stainless Steel	SUS403
Ball	Stainless Steel	SCS13A or SUS304 or SUS304TP
Grand packing	PTFE	
Gasket	PTFE	
Ball Seat	PTFE	
Cap bolt	Carbon Steel	
Handle	Ductile Iron	FCD400

Design Specifications

Items	
Shell wall thickness and general valve design	KITZ Standard
Face-to-face dimensions End-to-end dimensions*	JIS B2002
End flange dimensions Gasket contact facing	JIS B2239 10K

*Nominal size 5, shall not be in accordance with JIS B2002

For Pressure-Temperature Ratings, refer to individual catalog.

Dimensions

Valve Size	B	5	6	8	10	mm
	A	125	150	200	250	
L Face-to-face		250	270	290	330	
H Height		200	220	295	355	
D Handle		460	460	1000	1500	

*No JIS Mark

10K

IRON 3-WAY BALL VALVE (Full or Reduced bore)

Fig. 10FCTB2L

• Full Bore:
Size 1 1/2 to 4

Fig. 10FCTR2L

• Reduced Bore:
Size 5 to 8



Blowout-proof stem

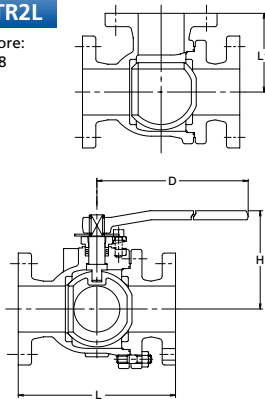

Materials

Parts	Material	JIS Spec.
Body	Cast Iron	FC200
Body cap	Cast Iron	FC200
Stem	Stainless Steel	SUS403
Ball	Stainless Steel	SCS13
Grand packing	PTFE	
Gasket	PTFE	
Ball Seat	PTFE	
Cap bolt/nut	Carbon Steel	
Handle	Ductile Iron	FCD400

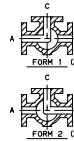

Note:

- Flow is between Ports "A" and "C" in Form 1. Flow is between Ports "B" and "C" in Form 2. Flow paths in Form 1 and Form 2 can be changed each other.
- When the fluid pressure P2 in the closed path is higher than P1 in the open path, a little fluid leakage may occur to P1 through the ball seat of the closed path.

Design Specifications

Items	
Shell wall thickness	JIS B2031
Face-to-face dimensions End-to-end dimensions	KITZ Standard
End flange dimensions Gasket contact facing	JIS B2239 10K

For Pressure-Temperature Ratings, refer to individual catalog.

Dimensions

Valve Size	B	1 1/2	2	2 1/2	3	4	5	6	8	mm
	A	40	50	65	80	100	125	150	200	
L Face-to-face		210	220	250	260	330	370	430	540	
L1		105	110	125	130	165	185	215	270	
H Height		115	120	155	165	200	205	225	295	
D Handle		230	230	400	400	460	460	460	1000	

CLASS 125 IRON BALL VALVE (Full bore)

Fig. 125FCTB



Blowout-proof stem

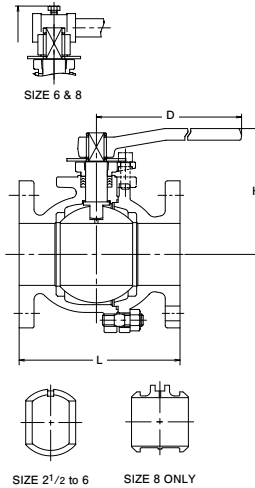

Materials

Parts	Material	ASTM Spec.
Body	Cast Iron	A126 CL. B
Body cap	Cast Iron	A126 CL. B
Stem	Stainless Steel	A276 Type403
Ball	Stainless Steel	A276 Type 304 or A312 Gr.TP304 or A351 Gr.CF8
Grand packing	PTFE	
Gasket	PTFE	
Ball Seat	PTFE	
Cap bolt	Carbon Steel	
Handle	Ductile Iron	

Design Specifications

Items	
Shell wall thickness and general valve design	KITZ Standard
Face-to-face dimensions End-to-end dimensions	ASME B16.10 Class150
End flange dimensions Gasket contact facing	ASME B16.1 Class125

For Pressure-Temperature Ratings, refer to individual catalog.

Dimensions

Valve Size	NPS DN	2	2 1/2	3	4	6	8	mm
L Face-to-face		178	190	203	229	394	457	
H Height		120	155	165	200	295	355	
D Handle		230	400	400	460	1000	1500	

CLASS 125 IRON BALL VALVE (Reduced bore)

Fig. 125FCTR



Blowout-proof stem

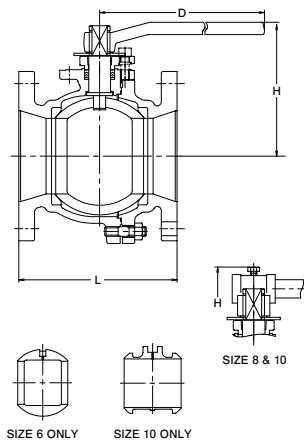

Materials

Parts	Material	ASTM Spec.
Body	Cast Iron	A126 CL. B
Body cap	Cast Iron	A126 CL. B
Stem	Stainless Steel	A276 Type403
Ball	Stainless Steel	A312 Gr.TP304 or A351 Gr.CF8
Grand packing	PTFE	
Gasket	PTFE	
Ball Seat	PTFE	
Cap bolt	Carbon Steel	
Handle	Ductile Iron	

Design Specifications

Items	
Shell wall thickness and general valve design	KITZ Standard
Face-to-face dimensions End-to-end dimensions	ASME B16.10 Class150
End flange dimensions Gasket contact facing	ASME B16.1 Class125

For Pressure-Temperature Ratings, refer to individual catalog.

Dimensions

Valve Size	NPS DN	6	8	10	mm
L Face-to-face		267	292	330	
H Height		220	295	355	
D Handle		460	1000	1500	

PIPE FLANGE DIMENSIONS

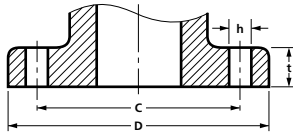

Class 125 ASME B16.1 - 2010

Nominal Size		D		C		t		h (Bolt Holes)		Bolting	
NPS	DN	in.	mm.	in.	mm.	in.	mm.	in.	mm.	Number	Diam. of bolt
1	25	4.25	108	3.12	79.5	0.44	11.2	5/8	16	4	1/2
1 1/4	32	4.62	117	3.50	89.0	0.50	12.7	5/8	16	4	1/2
1 1/2	40	5.00	127	3.88	98.5	0.56	14.3	5/8	16	4	1/2
2	50	6.00	152	4.75	120.5	0.62	15.9	3/4	19	4	5/8
2 1/2	65	7.00	178	5.50	139.5	0.69	17.5	3/4	19	4	5/8
3	80	7.50	190	6.00	152.5	0.75	19.1	3/4	19	4	5/8
4	100	9.00	229	7.50	190.5	0.94	23.9	3/4	19	8	5/8
5	125	10.00	254	8.50	216.0	0.94	23.9	7/8	22	8	3/4
6	150	11.00	279	9.50	241.5	1.00	25.4	7/8	22	8	3/4
8	200	13.50	343	11.75	298.5	1.12	28.6	7/8	22	8	3/4
10	250	16.00	406	14.25	362.0	1.19	30.2	1	25	12	7/8
12	300	19.00	483	17.00	432.0	1.25	31.8	1	25	12	7/8
14	350	21.00	533	18.75	476.5	1.38	35.0	1 1/8	29	12	1
16	400	23.50	597	21.25	539.5	1.44	36.6	1 1/8	29	16	1
18	450	25.00	635	22.75	578.0	1.56	39.7	1 1/4	32	16	1 1/8
20	500	27.50	699	25.00	635.0	1.69	42.9	1 1/4	32	20	1 1/8
24	600	32.00	813	29.50	749.5	1.88	47.8	1 3/8	35	20	1 1/4

Remarks: Dimensions of mm in the above table are converted from inch dimension, for your convenience.

PIPE FLANGE DIMENSIONS

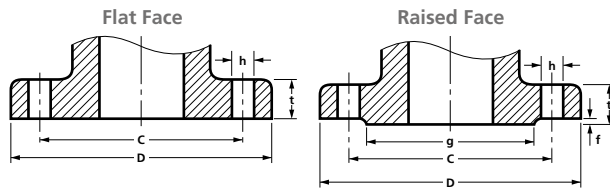

JIS 5K Cast iron pipe flange dimensions JIS B2239 - 2004

Unit: mm

Valve size		D	C	g	t	h	f	Bolt	
B	A				Cast iron			Number	Diam.
1 1/2	40	120	95	75	16	15	2	4	M12
2	50	130	105	85	16	15	2	4	M12
2 1/2	65	155	130	110	18	15	2	4	M12
3	80	180	145	121	18	19	2	4	M16
4	100	200	165	141	20	19	2	8	M16
5	125	235	200	176	20	19	2	8	M16
6	150	265	230	206	22	19	2	8	M16
8	200	320	280	252	24	23	2	8	M20
10	250	385	345	317	26	23	2	12	M20
12	300	430	390	360	28	23	3	12	M20
14	350	480	435	403	30	25	3	12	M22

JIS 10K Cast iron pipe flange dimensions JIS B2239 - 2004

Unit: mm

Valve size		D	C	g	t	h	f	Bolt	
B	A				Cast iron			Number	Diam.
3/8	10	90	65	46	14	15	1	4	M12
1/2	15	95	70	51	16	15	1	4	M12
3/4	20	100	75	56	18	15	1	4	M12
1	25	125	90	67	18	19	1	4	M16
1 1/4	32	135	100	76	20	19	2	4	M16
1 1/2	40	140	105	81	20	19	2	4	M16
2	50	155	120	96	20	19	2	4	M16
2 1/2	65	175	140	116	22	19	2	4	M16
3	80	185	150	126	22	19	2	8	M16
4	100	210	175	151	24	19	2	8	M16
5	125	250	210	182	24	23	2	8	M20
6	150	280	240	212	26	23	2	8	M20
8	200	330	290	262	26	23	2	12	M20
10	250	400	355	324	30	25	2	12	M22
12	300	445	400	368	32	25	3	16	M22
14	350	490	445	413	34	25	3	16	M22
16	400	560	510	475	36	27	3	16	M24
18	450	620	565	530	38	27	3	20	M24
20	500	675	620	585	40	27	3	20	M24
24	600	795	730	690	44	33	3	24	M30

TEMPERATURE-PRESSURE TABLE FOR SATURATED-VAPOUR

Temperature			Pressure (abs.)			Pressure (G)		
Temperature °C	Pressure (abs.) MPa	Pressure (G) MPa	Pressure (abs.) MPa	Pressure (G) MPa	Satulation Temperature °C	Pressure (G) MPa	Pressure (abs.) MPa	Satulation Temperature °C
70	0.03	-0.07	0.09	-0.01	99.1	0	0.10	100.0
80	0.05	-0.05	0.19	0.09	119.6	0.09	0.19	120.1
90	0.07	-0.03	0.29	0.19	132.9	0.19	0.29	133.2
100	0.10	0	0.39	0.29	142.9	0.29	0.39	143.2
110	0.14	0.04	0.49	0.39	151.1	0.39	0.49	151.3
120	0.19	0.09	0.58	0.48	158.1	0.49	0.59	158.3
130	0.26	0.16	0.68	0.58	164.2	0.58	0.68	164.3
140	0.36	0.26	0.78	0.68	169.6	0.68	0.78	169.8
150	0.47	0.37	0.88	0.78	174.5	0.78	0.88	174.7
160	0.61	0.51	0.98	0.88	179.0	0.88	0.98	179.3
170	0.79	0.69	1.17	1.07	187.1	0.98	1.08	183.2
180	1.00	0.90	1.37	1.27	194.1	1.17	1.27	190.0
190	1.25	1.15	1.56	1.46	200.4	1.37	1.47	197.4
200	1.55	1.45	1.76	1.66	206.2	1.56	1.66	203.4
210	1.90	1.80	1.96	1.86	211.4	1.78	1.88	208.9
220	2.32	2.21	2.45	2.35	222.9	1.96	2.06	213.8
230	2.79	2.69	2.94	2.84	232.8	2.45	2.55	223.8
240	3.34	3.24	3.43	3.33	241.4	2.94	3.04	234.5
250	3.97	3.87	3.92	3.82	249.2	3.92	4.02	250.6
260	4.66	4.56	4.90	4.80	262.7	4.90	5.00	263.9
270	5.50	5.40	5.88	5.78	274.3	5.88	5.98	275.3
280	6.41	6.31	6.86	6.76	284.5	6.86	6.96	285.4
290	7.44	7.34	7.84	7.74	293.6	7.84	7.94	294.5
300	8.59	8.49	8.82	8.72	301.9	8.82	8.92	302.7
310	9.87	9.77	9.80	9.70	309.5	9.80	9.90	310.9
320	11.28	11.18	11.76	11.66	323.1	11.76	11.86	323.8
330	12.86	12.76	13.72	13.62	335.1	13.72	13.82	335.6
340	14.61	14.51	15.69	15.59	345.7	15.69	15.79	346.2
350	16.47	16.37	17.65	17.55	355.4	17.65	17.75	355.8
360	18.77	18.67	19.61	19.51	364.1	19.61	19.71	364.5
370	21.15	21.05	21.57	21.47	372.0	21.57	21.67	372.5

CAUTION

Pressure-temperature ratings and other performance data published in this catalog have been developed from our design calculation, in-house testing, field reports provided by our customers and / or published official standards or specifications. They are good only to cover typical applications as a general guideline to users of KITZ products introduced in this catalog.

For any specific application, users are kindly requested to contact KITZ Corporation for technical advice, or to carry out their own study and evaluation for proving suitability of these products to such an application. Failure to follow this request could result in property damage and / or personal injury, for which we shall not be liable.

While this catalog has been compiled with the utmost care, we assume no responsibility for errors, impropriety or inadequacy. Any information provided in this catalog is subject to from-time-to-time change without notice for error rectification, product discontinuation, design modification, new product introduction or any other cause that KITZ Corporation considers necessary. This edition cancels all previous issues.

Read instruction manual carefully before use.

NOTICE

If any products designated as strategic material in the Foreign Exchange and Foreign Trade Law, Cabinet Order Concerning Control of Export Trade, Cabinet Order Concerning Control of Foreign Exchange and other related laws and ordinances ("Foreign Exchange Laws") are exported to any foreign country or countries, an export license issued by the Japanese Government will be required under the Foreign Exchange Laws.

Further, there may be cases where an export license issued by the government of the United States or other country will be required under the applicable export-related laws and ordinances in such relevant countries.

The contract shall become effective subject to that a relevant export license is obtained from the Japanese Government.

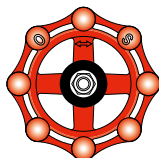

*A chrysanthemum-handle is a symbol of KITZ,
the brand of valve reliability*

ISO 9001 certified since 1989

KITZ
KITZ CORPORATION

1-10-1, Nakase, Mihama-ku, Chiba 261-8577, Japan
International Sales Dept.

Phone : 81-43-299-1730, 1732 and 1733

Fax : 81-43-299-0121

— Distributed by —